

Cavity-Tooling:08W-4

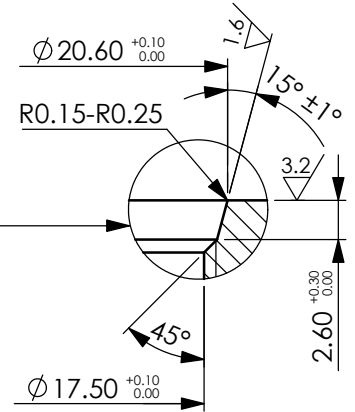

General tolerance:  $\pm 0.3$   
UNIT:mm

Cavity-Tooling:10W-4

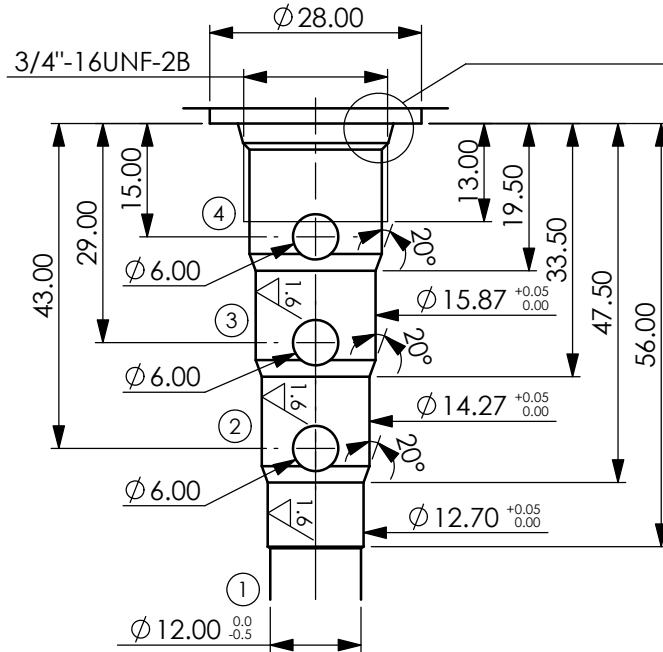
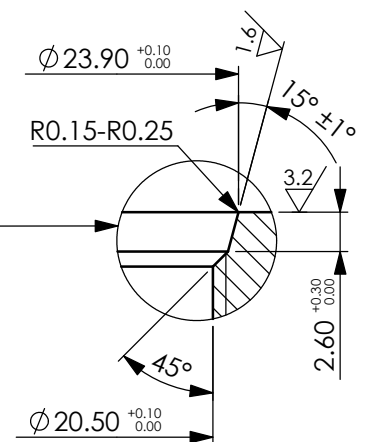
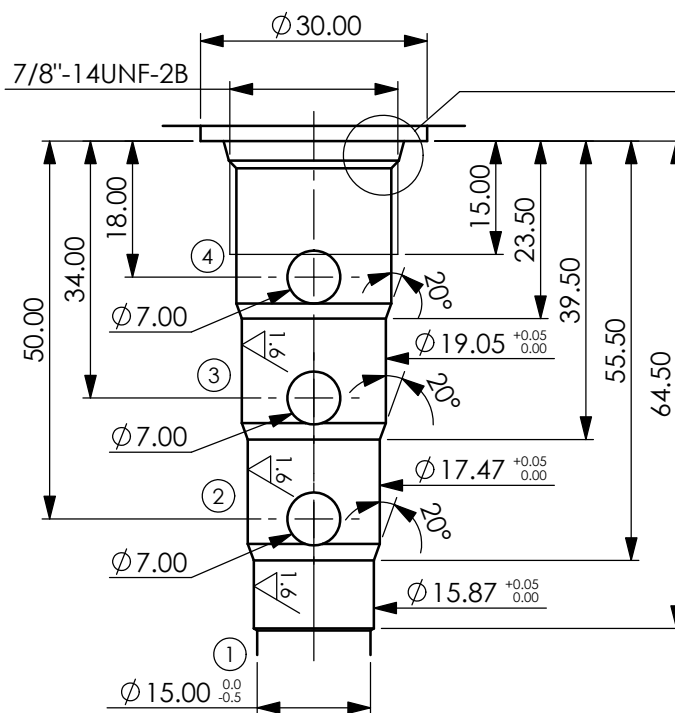

General tolerance:  $\pm 0.3$   
UNIT:mm