

Cavity-Tooling:13A-2

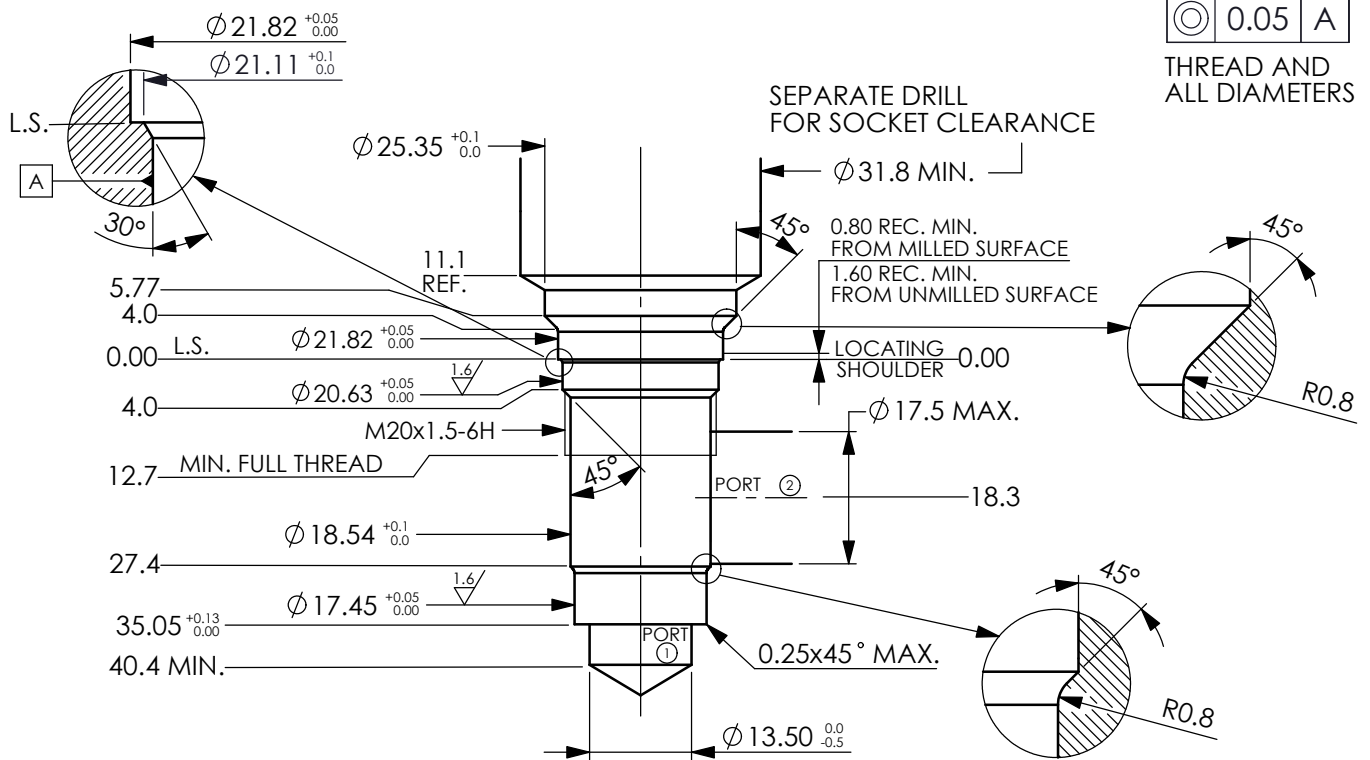

0.05 A
THREAD AND ALL DIAMETERS

Cavity-Tooling:5A-2

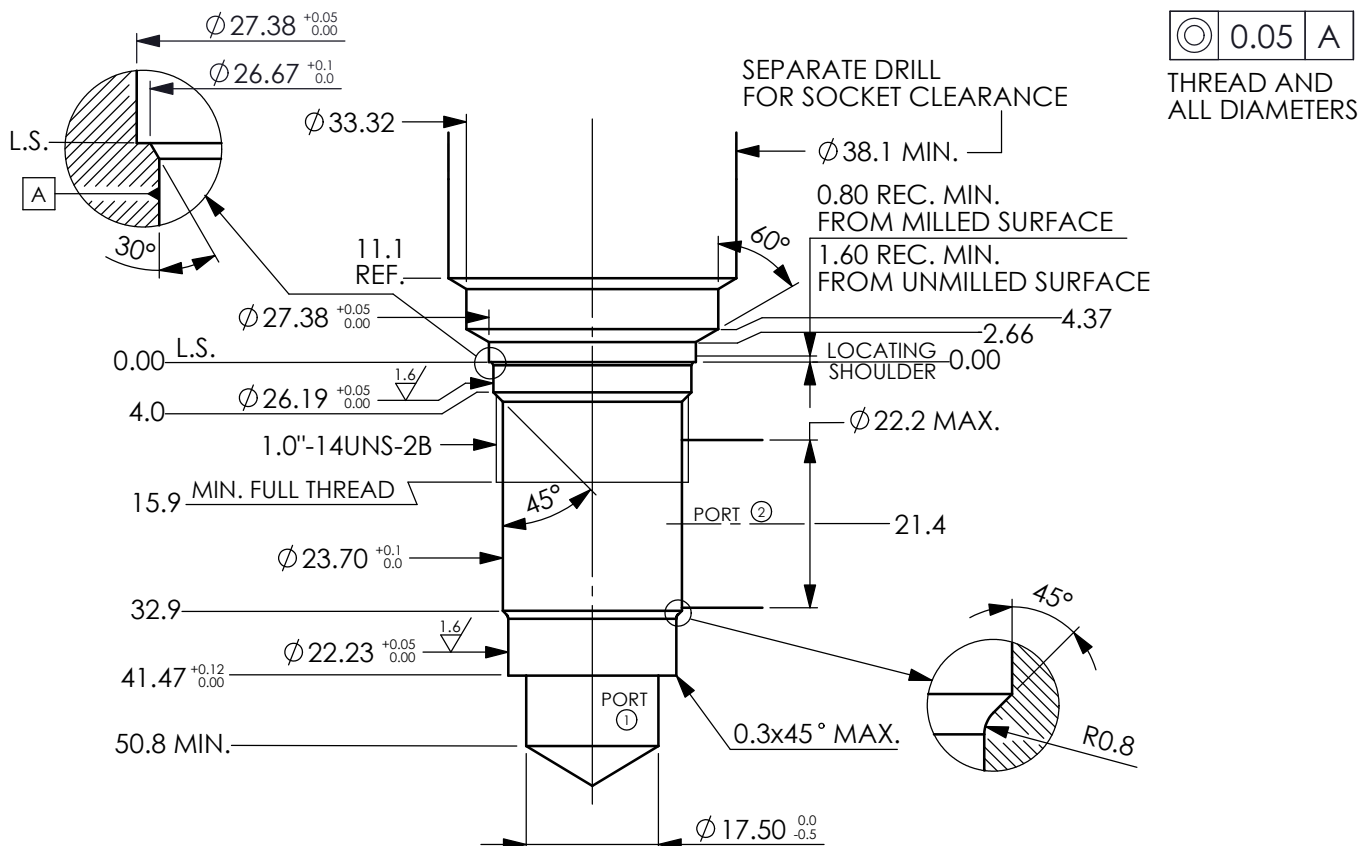

0.05 A
THREAD AND ALL DIAMETERS