

ISO 03 SANDWICH MANIFOLD

Ordering Code: **MH03PAF-X-Y-Z 01**

Stack Height : 44.5mm

Technical drawing showing dimensions and port locations (A, B, P, T) for the ISO 03 Sandwich Manifold. Dimensions include 78.4, 57.2, 71.1, 206.7, and 44.5 mm. A hole diameter is specified as $\phi 5.4^{+0.10}_{0.00}$. The O-RING CODE NO. is 4KAA012AA001.

UNIT:mm

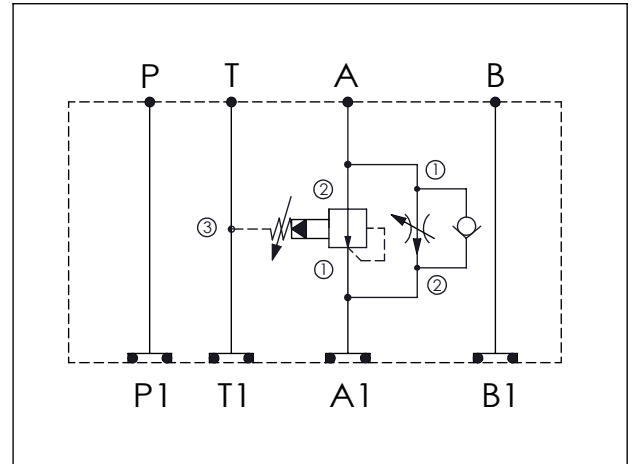

TECHNICAL DATA

Aluminum Body Pressure Rating: 210 bar
 Ductile Iron
 Body Pressure Rating: 350 bar

Rated flow: 40 l/min

Cartridge Valve:
 Refer to PB11A-X-Y-Z
 FR13A-X-Y-Z

* Refer to Winner Cartridge Valves Catalog.

Aluminum	0.46 kg(WITHOUT VALVES) 0.76 kg(INCLUDE VALVES)

* If you need the special specification.
 Please contact us.

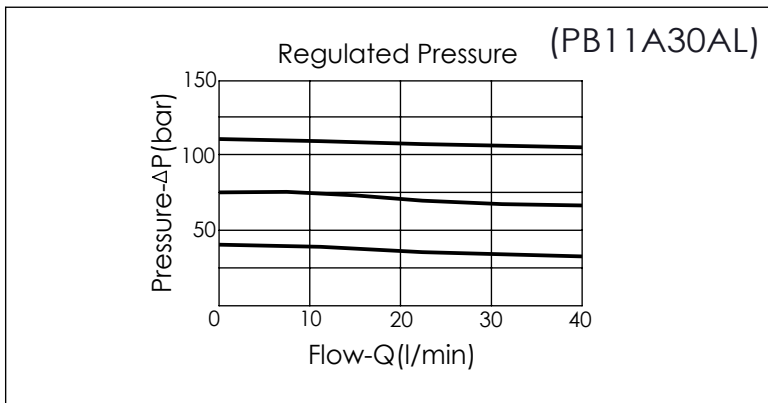

X	SELECTION FOR A PORT CONTROL
11A3	CAVITY ONLY(WITHOUT VALVE)
PB0A	PB11A30AL (40LPM , 7-210bar)
Please refer to the list price of cartridge program.	

Y	SELECTION FOR B PORT CONTROL
13A2	CAVITY ONLY(WITHOUT VALVE)
FR0A	FR13A20AL (23LPM,350bar)
Please refer to the list price of cartridge program.	

Z	BODY MATERIAL
A	HIGH-STRENGTH ALUMINUM