

Ordering Code: **MM-60-CAK-X-Y-Z 02**

Stack Height : 39.5mm

Mounting Holes:
10.5mm diameter
through hole
2 places.

Turn screw clockwise to reduce setting and release load. Complete adjustment range in 3 turns

O-RING CODE NO.
4KAA119BA001

UNIT:mm

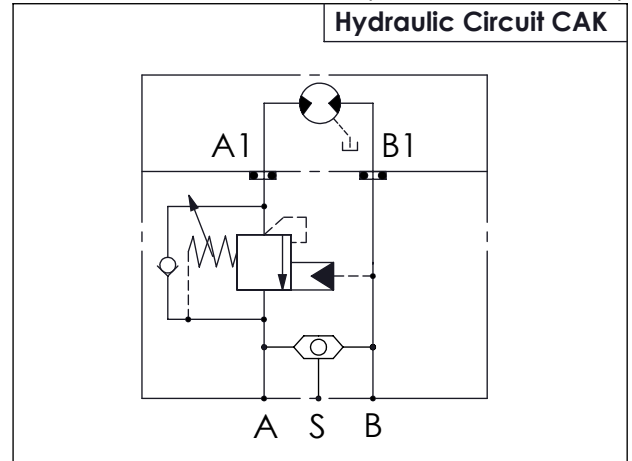

TECHNICAL DATA

Aluminum Body Pressure Rating: 210 bar

Rated flow: 60 l/min

Cartridge Valve:
Refer to CB11A-X-Y-Z

* Reference our Cartridge Valves Catalog.

Weight: 0.74 kg(include valve)

* If you need the special specification. Please contact us.

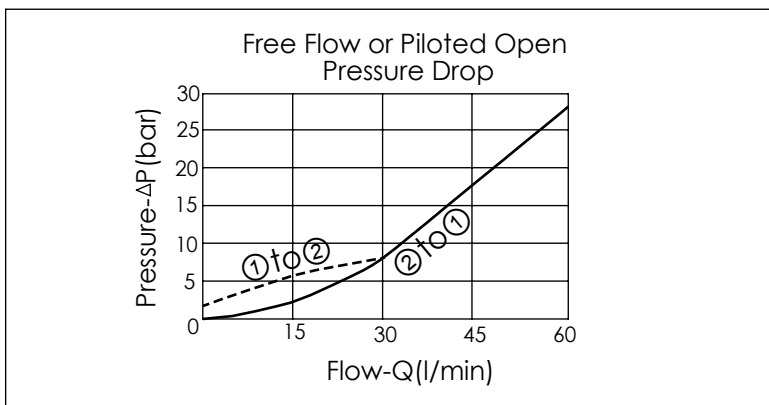

X	SELECTION FOR COUNTERBALANCE VALVES
11A3	CAVITY ONLY(WITHOUT VALVE)
CB3H	CB11A33HL (3:1 , 280bar)
CB4J	CB11A34JL (4.5:1 , 350bar)
CB0J	CB11A30JL (10:1 , 350bar)

Please refer to the list price of cartridge program.

Y	PORT SIZE	
	PORTS A.B	PORT S
G04	G 1/2"	G 1/4"

Z	BODY MATERIAL
A	HIGH-STRENGTH ALUMINUM